

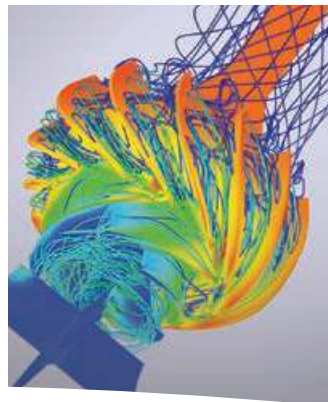

VPC
Vertical Turbine, Double Case Pump



Experience In Motion



Pump Supplier to the World

Flowserve is the driving force in the global industrial pump marketplace. No other pump company in the world has the depth or breadth of expertise in the successful application of pre-engineered, engineered, and special purpose pumps and systems.

Life Cycle Cost Solutions

Flowserve provides pumping solutions that permit customers to reduce total life cycle costs and improve productivity, profitability and pumping system reliability.

Market-Focused Customer Support

Product and industry specialists develop effective proposals and solutions directed toward market and customer preferences. They offer technical advice and assistance throughout each stage of the product life cycle, beginning with the initial inquiry.

Broad Product Lines

Flowserve offers a wide range of complementary pump types, from pre-engineered process pumps to highly engineered and special purpose pumps and systems. Pumps are built to recognized global standards and customer specifications.

Pump designs include:

- Single-stage process
- Between bearings single-stage
- Between bearings multistage
- Vertical
- Submersible motor
- Positive displacement
- Nuclear
- Specialty

Product Brands of Distinction

ACEC™

Aldrich™

Byron Jackson®

Calder™ Energy Recovery Devices

Cameron™

Durco®

Flowserve®

HALBERG™

IDP®

INNOMAG®

Lawrence Pumps®

Niigata Worthington™

Pacific®

Pleuger®

Scienco™

Sier-Bath®

SIHI®

TKL™

United Centrifugal®

Western Land Roller™

Wilson-Snyder®

Worthington®

Worthington Simpson™

VPC
Vertical Turbine,
Double Case
Pump



Complementary Pump Designs

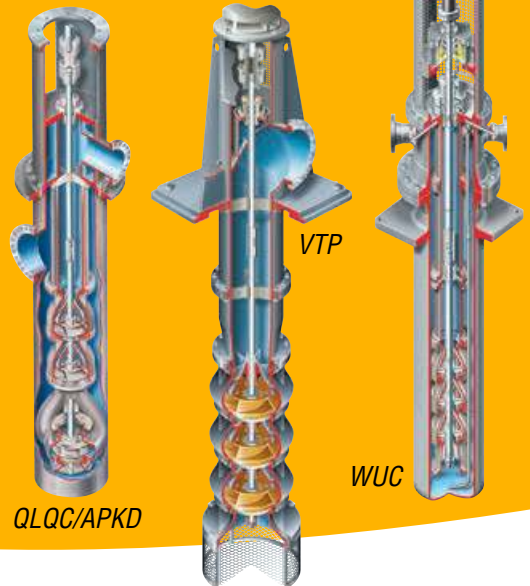

Unequaled Hydraulic Coverage
and Design Flexibility

The Flowserve VPC is a double case, diffuser type, vertical turbine pump. Available in single or multistage construction, as well as standard and ISO 13709/API 610 compliant designs, the VPC incorporates the proven hydraulics of the Flowserve VTP vertical turbine pump into a double case configuration. It is designed for continuous duty applications and is particularly well suited for services with limited NPSH.

Engineered Flexibility

VPC pumps are available in a wide variety of configurations, constructions and materials to suit application requirements. Among the options are:

- Standard and ISO 13709/API 610 (VS6), latest edition configurations
- Enclosed or semi-open impellers, keyed or collet mounted
- Bowl and enclosed impeller wear rings
- Fabricated steel discharge head and suction can
- Sealing configurations
 - Packed box with flexible graphite packing
 - Single- or dual-mechanical seal
- Above- or below-ground suction flanges
- Multiple drivers
 - Electric motors, solid or hollow shaft
 - Engines with right angle gears
 - Steam turbines
- Internal and external suction can drains
- Separate axial thrust bearing assembly

Applications

- Hydrocarbon booster
- Hydrocarbon transfer
- Pipeline booster
- Petrochemical transfer
- Condensate
- Water supply
- Water transfer
- Snowmaking
- Brine injection
- Heater drain

Complementary Pump Designs

Flowserve also can provide the following complementary pumps:

- VTP vertical turbine, wet-pit pump
- APKD, QLC and QLQC double case, double-suction, double volute pumps
- WUC ISO 13709/API 610 (VS6) vertical, multistage, double case process pump
- VCT vertical mixed flow pump
- LNN between bearing, axially split, single-stage, double-suction pump

VPC
Vertical Turbine, Double
Case Pump

The VPC is designed for a variety of applications where a wet well is not available or there is limited NPSH available. Its broad hydraulic coverage is well complemented by its versatility in applications. The VPC meets the design requirements of international standards, including ANSI, AWWA, ASME and Hydraulic Institute.

Operating Parameters

- Flows to 13 600 m³/h (60 000 gpm)
- Heads to 1070 m (3500 ft)
- Pressures to 100 bar (1450 psi)
- Temperatures from -45°C (-50°F) to 230°C (450°F)

Features and Benefits

Solid Shaft Motor includes thrust bearing to withstand the total hydraulic thrust as well as the rotor weight. Shaft extension allows the motor to be coupled to the pump.

Fabricated Steel Discharge Head with ASME Class 150 or 300 slip-on flanges. Functions as a mounting base for the motor or other driver combination.

Rigid, Adjustable Flanged Coupling provides the proper impeller clearance adjustment.

Fabricated Steel Suction Can creates optimum hydraulic conditions through the suction flange inlet into the suction bell.

Open Lineshaft Construction allows the lineshaft bearings to be lubricated by the pumped fluid.

Bowls are designed with multiple diffuser vanes and flanged construction. Bowl bearings on either side of the impeller provide rigid support to the shaft.

Enclosed or Semi-open Impellers are cast to provide smooth passageways for more efficient fluid flow. First-stage impeller is available with low NPSH design.

Suction Bell is designed to provide efficient fluid flow into the eye of the first-stage impeller.

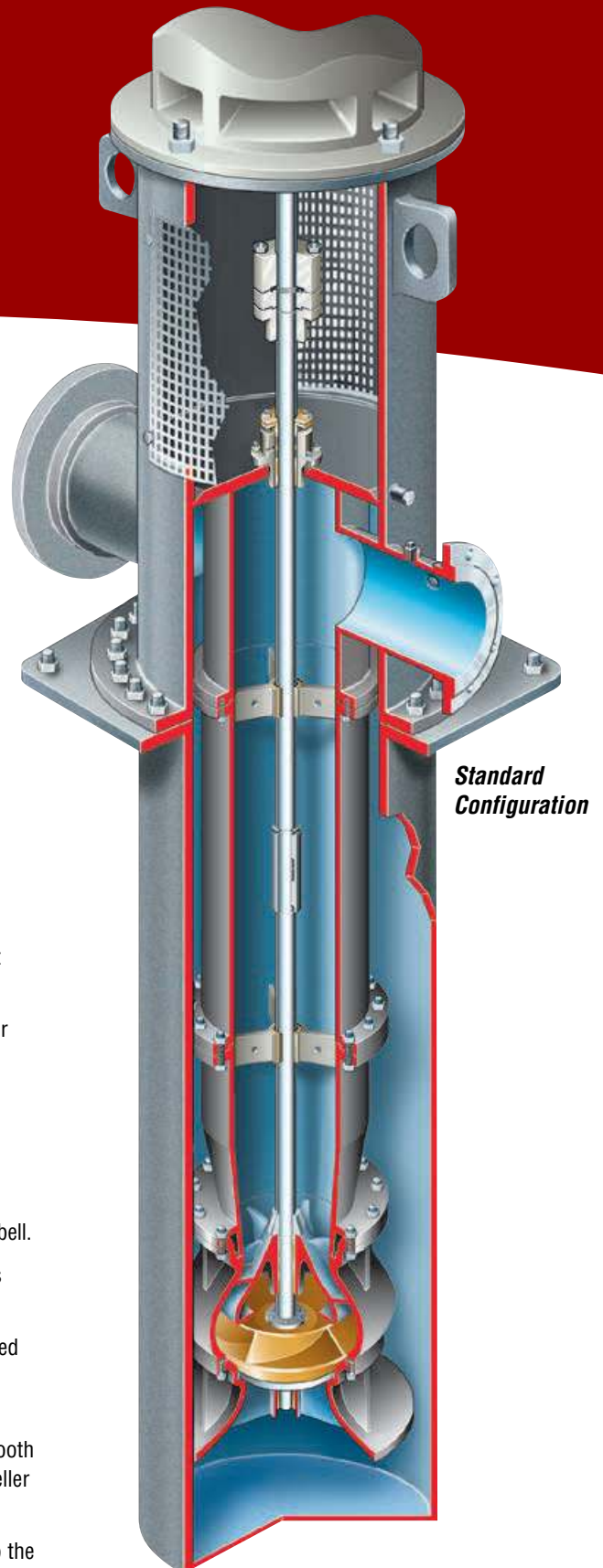

VPC
ISO 13709/API 610 (VS6)
Vertical Turbine, Double
Case Pump

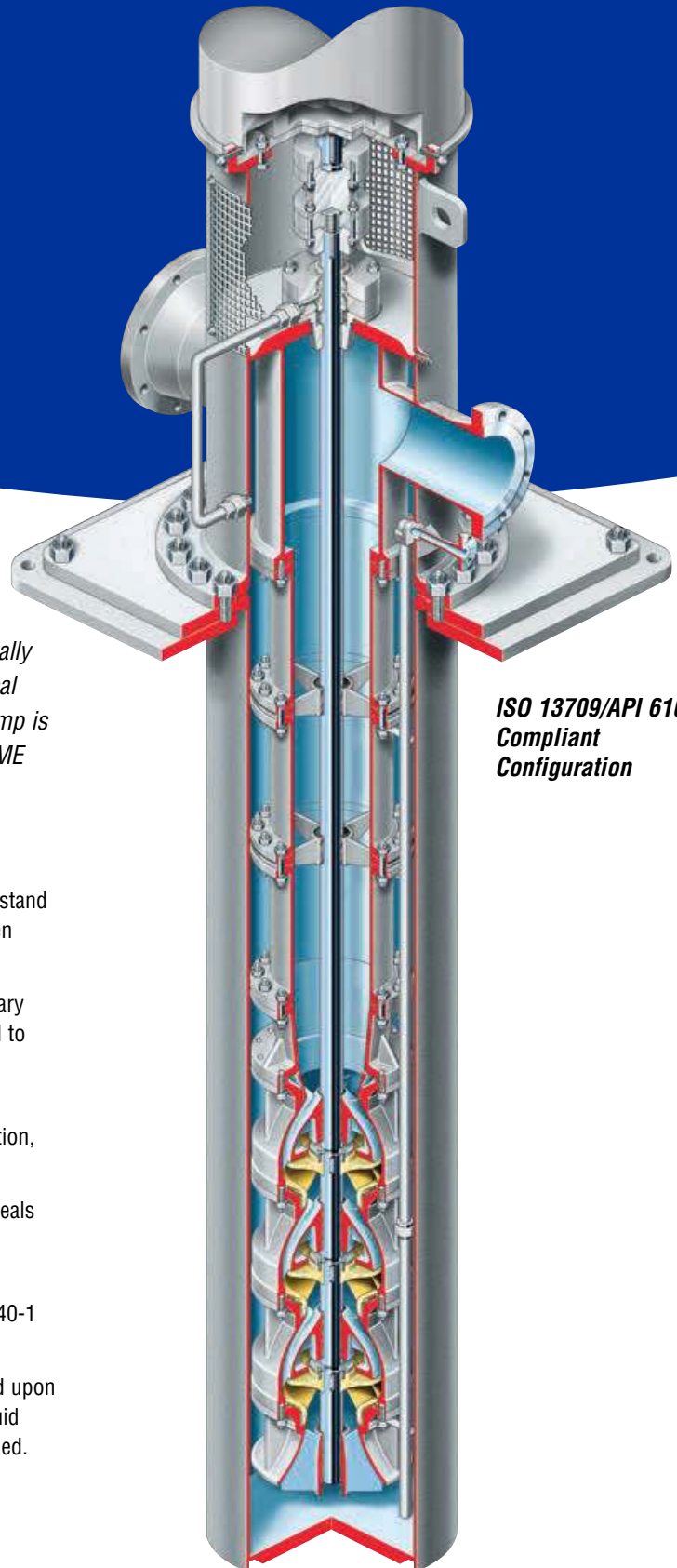

Design flexibility makes the VPC ideal for process applications. For the aggressive applications typically found in the oil and gas, hydrocarbon and chemical industries, a heavy-duty VPC is available. This pump is compliant with ISO 13709/API 610 (VS6) and ASME Section VIII and IX design requirements.

Features and Benefits

Heavy-duty ASME Pressure Casing is designed to withstand the maximum allowable working pressure (MAWP), even under API's specified corrosion conditions.

Weld-neck Flanges on all suction, discharge and auxiliary connections provide increased MAWP and are designed to withstand API nozzle loadings.

One-piece Pump Shaft eliminates threaded lineshaft couplings and the increased shaft run-out, higher vibration, and weaker joints associated with them.

Seal Chamber with jackscrews accepts single or dual seals and enables mating parts to be separated easily during disassembly. Plan 13 provides continuous venting.

Dynamically Balanced Enclosed Impellers per ISO 1940-1 grade G2.5.

Flanged Vent Connection allows the pump to be vented upon initial operation. It can also be pressurized to purge liquid from the suction can when a suction can drain is supplied.

Studs and Nuts prevent thread damage common with capscrew removal.

Precision Rigid, Adjustable Flanged Spacer Coupling provides easy impeller lift adjustment and allows seal removal without disturbing the motor.

ISO 13709/API 610
Compliant
Configuration

Options and Technical Data

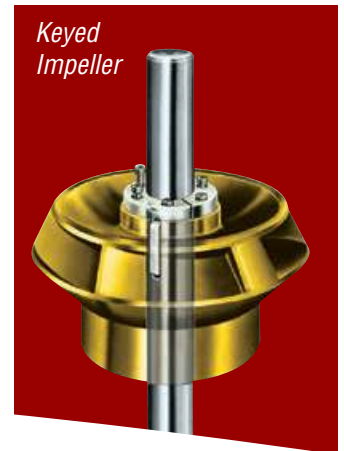
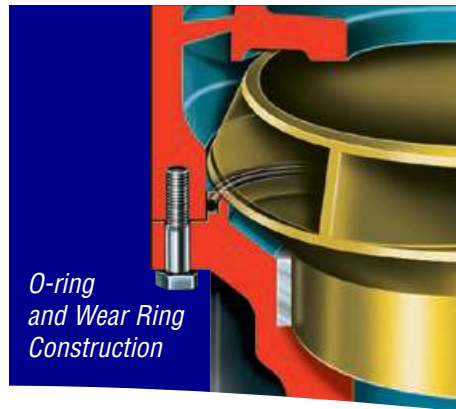
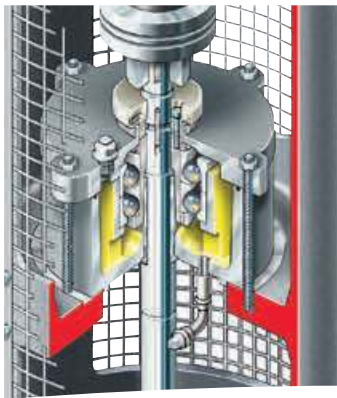

Integral Axial Thrust Bearing Assembly

The axial thrust bearing assembly withstands the total hydraulic thrust as well as the rotor weight. Self-lubricating, anti-friction bearings are utilized for standard applications. The integral axial thrust bearing assembly is available on VPC pumps with IEC motors.

Mechanical Seal

- Pressures to 105 bar (1500 psi)
- No leakage
- Easy access for maintenance and parts replacement
- Single and dual arrangements are available
- Multiple seal piping plans are available

Available Options

- O-ring construction
- Bowl and impeller wear rings
- Keyed impellers

Suction Configurations

VPC pumps are available with above- or below-ground suction flanges to suit site conditions.

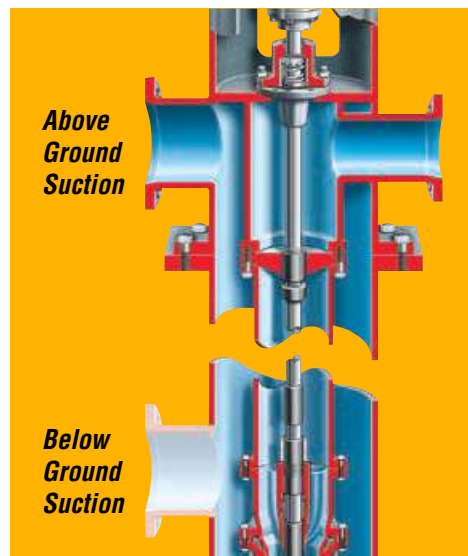

Range Chart

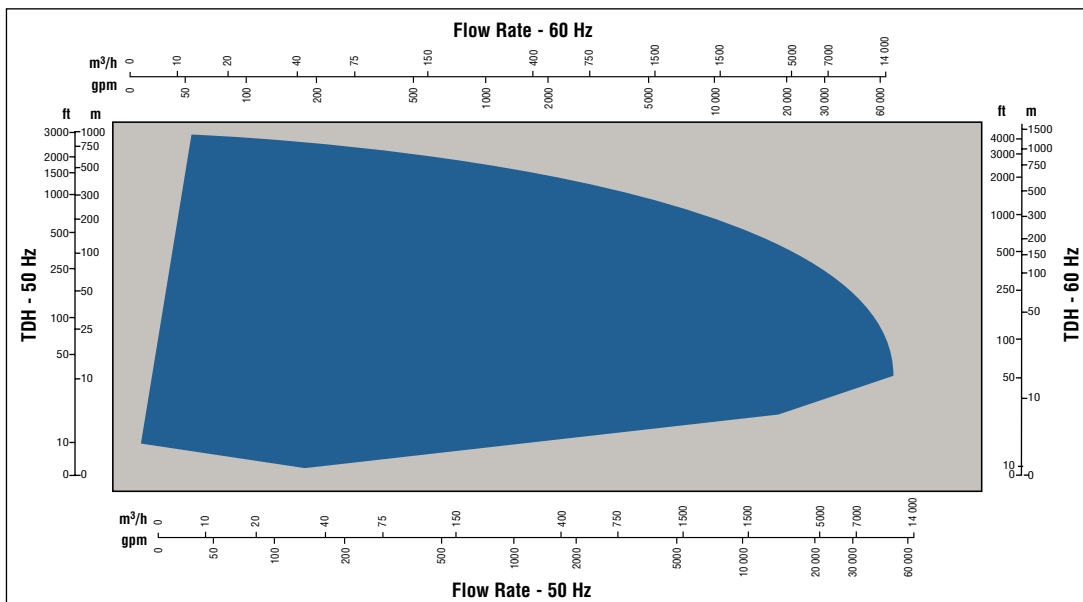

Global Service
and Technical
Support



Life Cycle Cost Solutions

Typically, 90% of the total life cycle cost (LCC) of a pumping system is accumulated after the equipment is purchased and installed. Flowserve has developed a comprehensive suite of solutions aimed at providing customers with unprecedented value and cost savings throughout the life span of the pumping system. These solutions account for every facet of life cycle cost, including:

Capital Expenses

- Initial purchase
- Installation

Operating Expenses

- Energy consumption
- Maintenance
- Production losses
- Environmental
- Inventory
- Operating
- Removal

Innovative Life Cycle Cost Solutions

- New Pump Selection
- Turnkey Engineering and Field Service
- Energy Management
- Pump Availability
- Proactive Maintenance
- Inventory Management

Typical Pump Life Cycle Costs¹

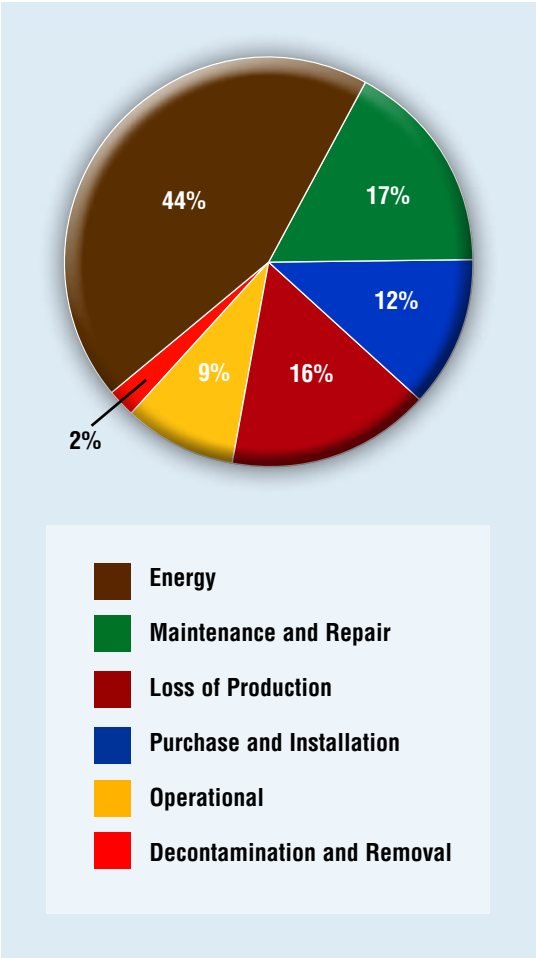

¹ While exact values may differ, these percentages are consistent with those published by leading pump manufacturers and end users, as well as industry associations and government agencies worldwide.

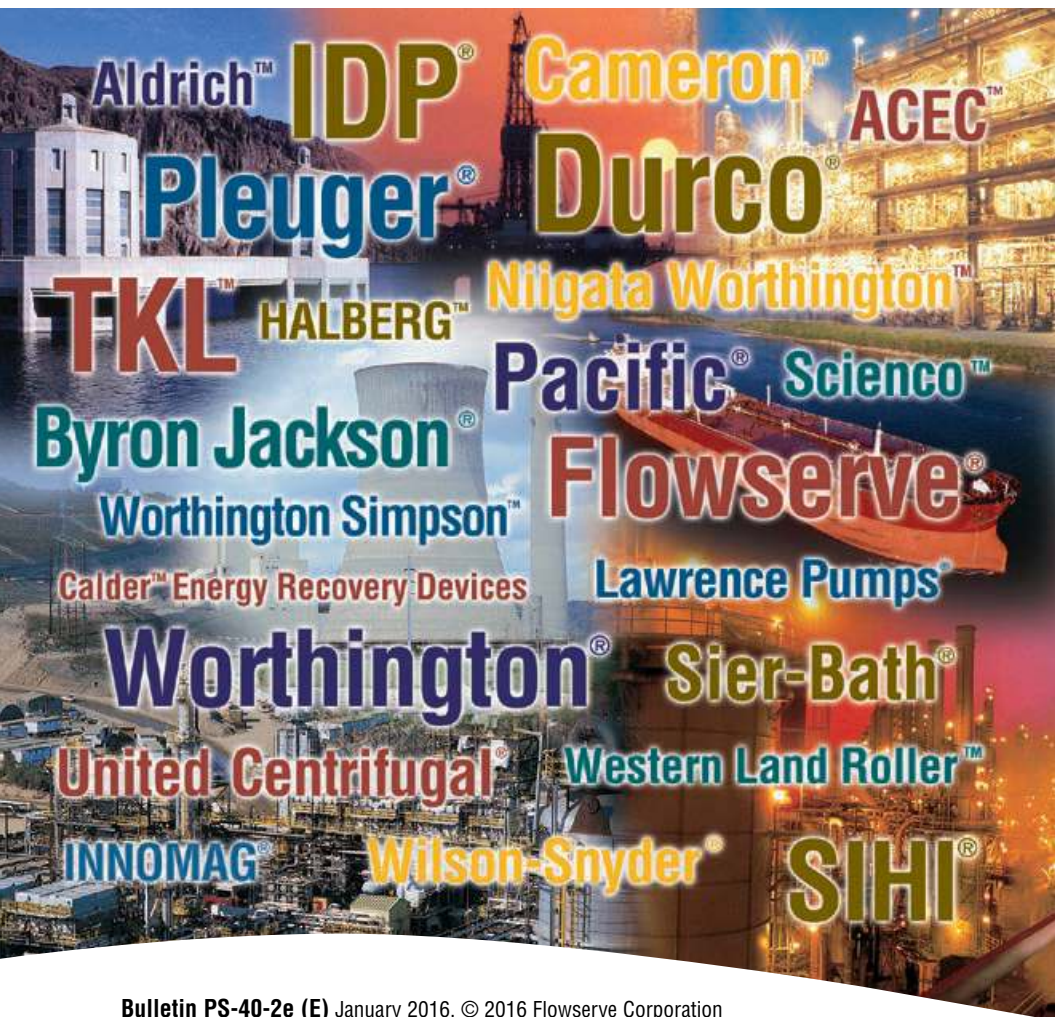

USA and Canada

Flowserve Corporation
5215 North O'Connor Blvd.
Suite 2300
Irving, Texas 75039-5421 USA
Telephone: +1 937 890 5839

Europe, Middle East, Africa

Flowserve Corporation
Parallelweg 13
4878 AH Etten-Leur
The Netherlands
Telephone: +31 76 502 8100

Latin America

Flowserve Corporation
Martín Rodríguez 4460
B1644CGN-Victoria-San Fernando
Buenos Aires, Argentina
Telephone: +54 11 4006 8700
Telefax: +54 11 4714 1610

Asia Pacific

Flowserve Pte. Ltd.
10 Tuas Loop
Singapore 637345
Telephone: +65 6771 0600
Telefax: +65 6862 2329

Bulletin PS-40-2e (E) January 2016. © 2016 Flowserve Corporation

To find your local Flowserve representative:

For more information about Flowserve Corporation,
visit www.flowserve.com or call +1 937 890 5839.